

3/4" Plywood

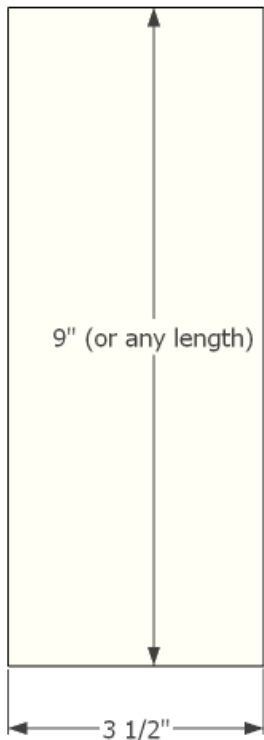

2x4 scrap lumber

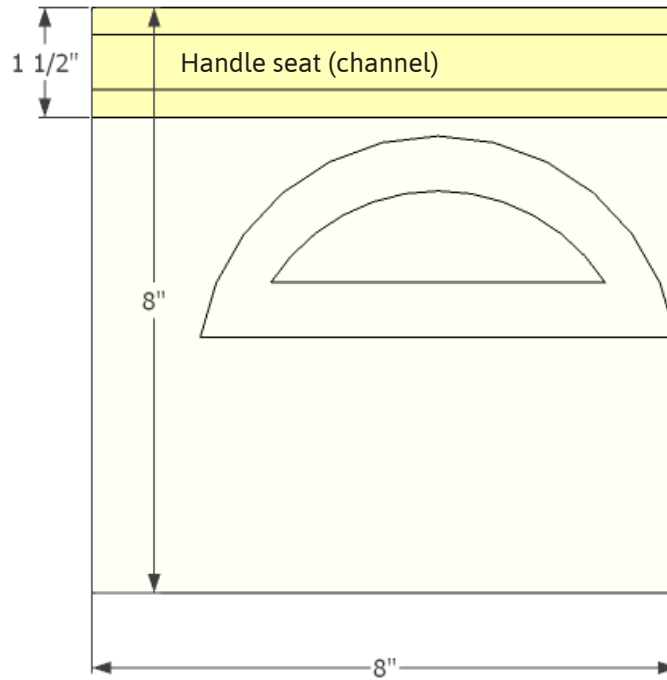

3/4" Plywood

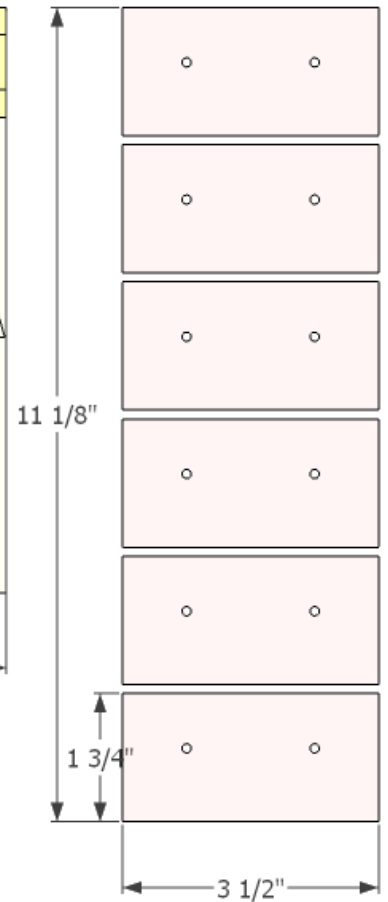

1/4" Plywood

Cut dado in oversized board.

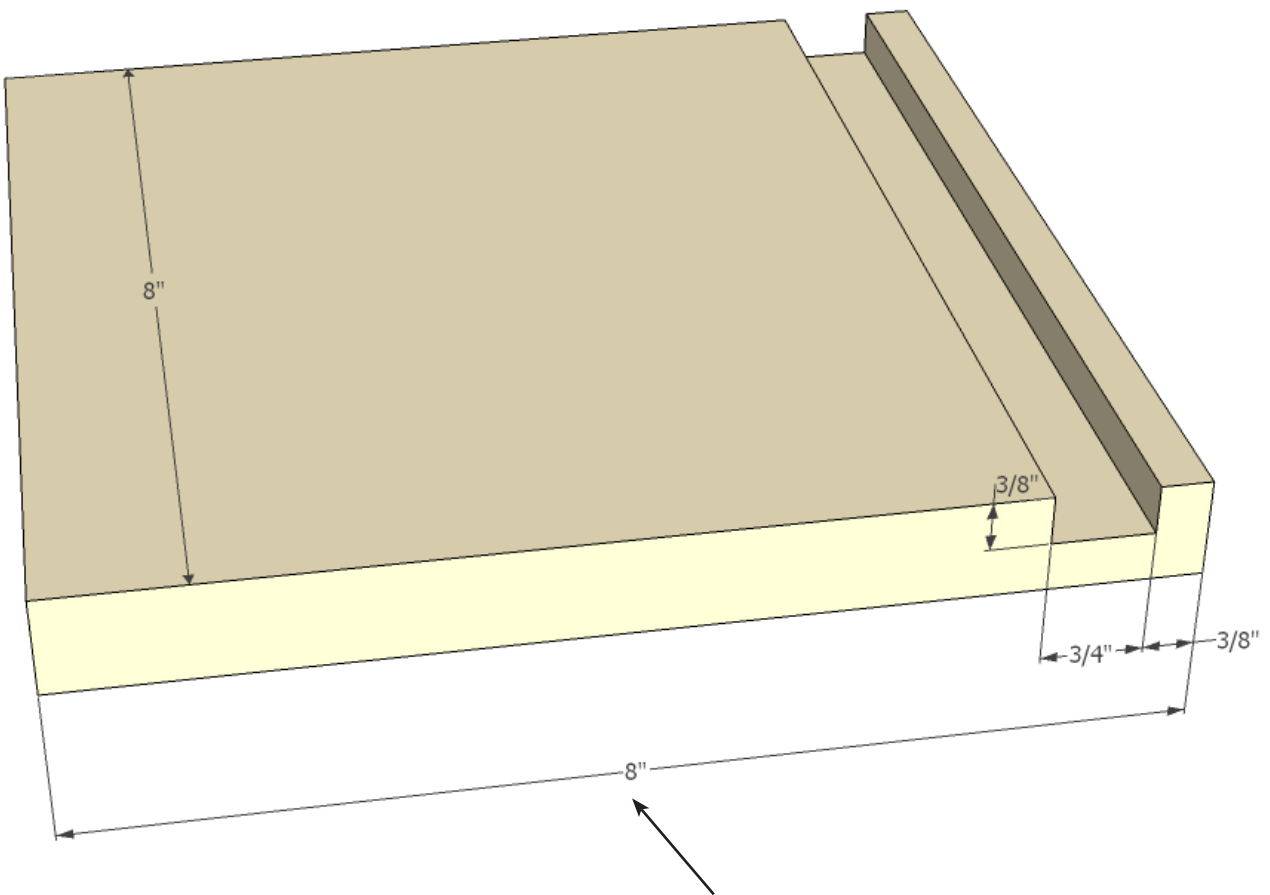

This can be any width, just make it wide enough to control cutting the dado with your fingers out of the way.

Cut handle seat to width and drill holes near the ends.

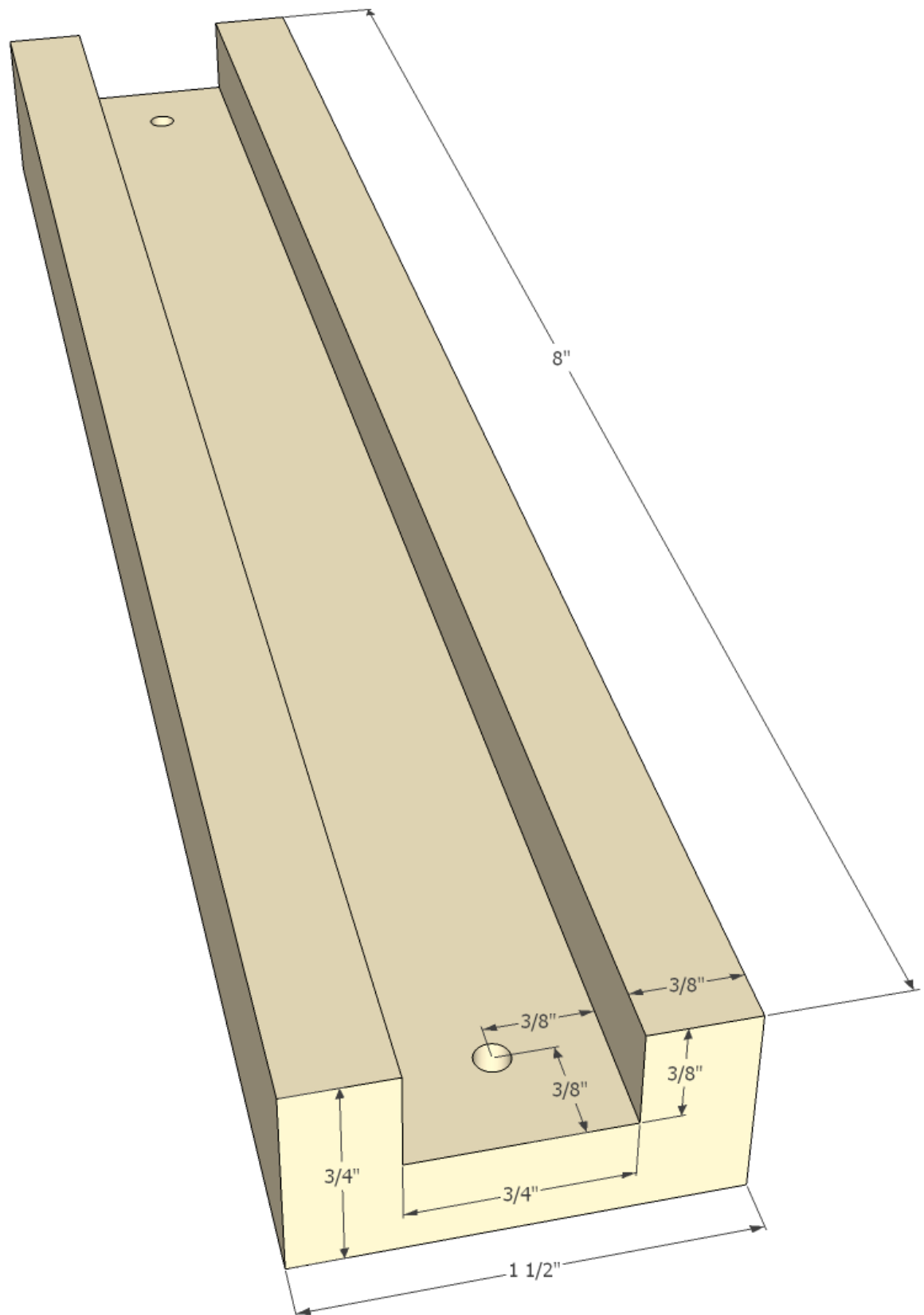

Cut and shape handle using a jigsaw.

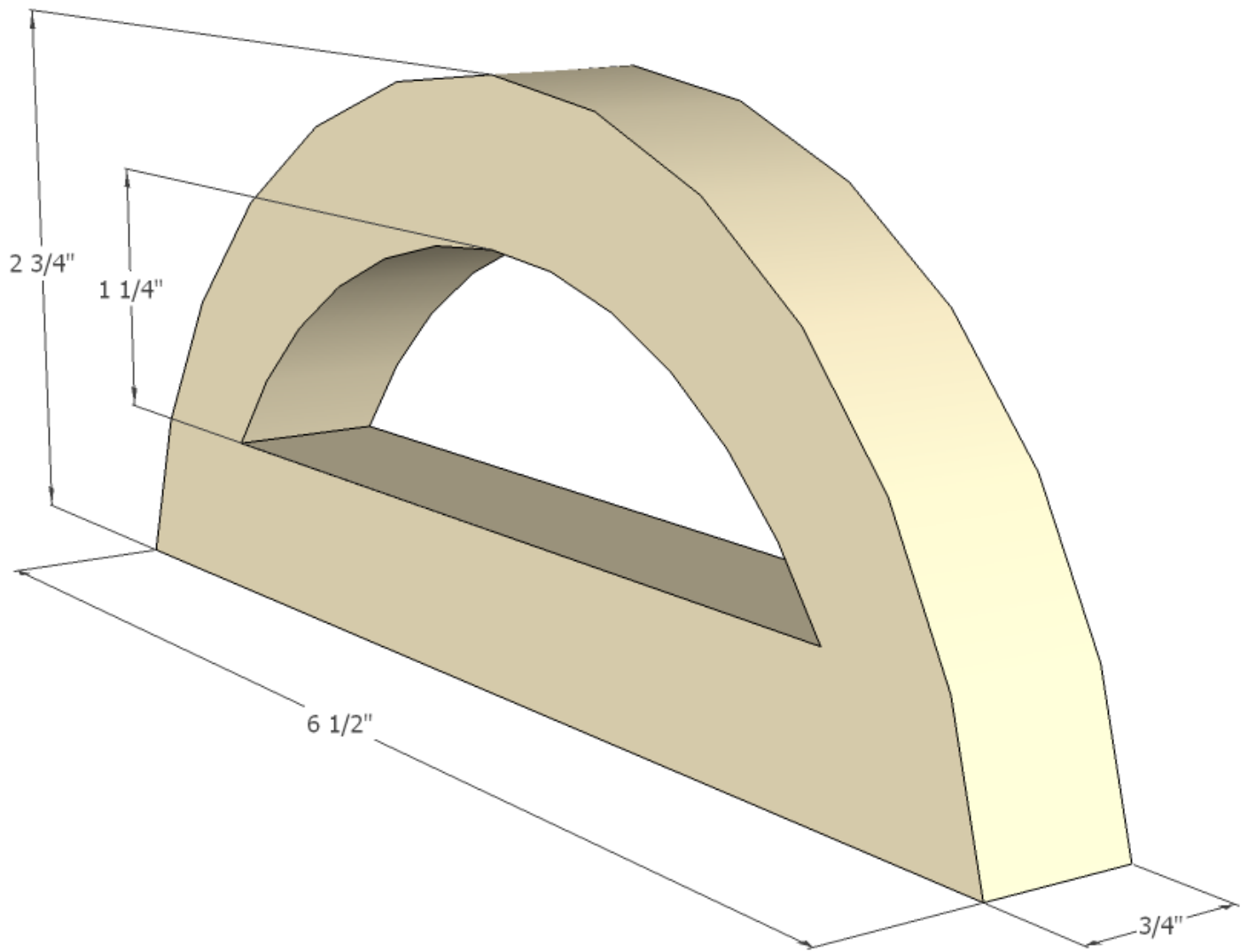

Full size cutting template.

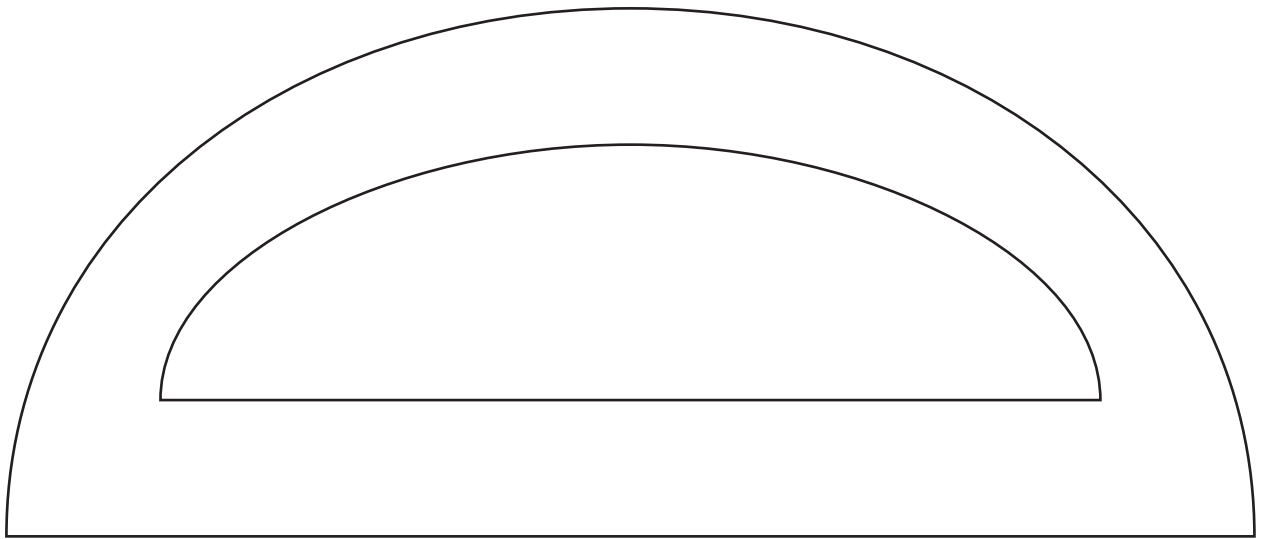

Cut 2x4 block to any length you want.
Cut cleats out of 1/4" plywood and drill holes for screws.

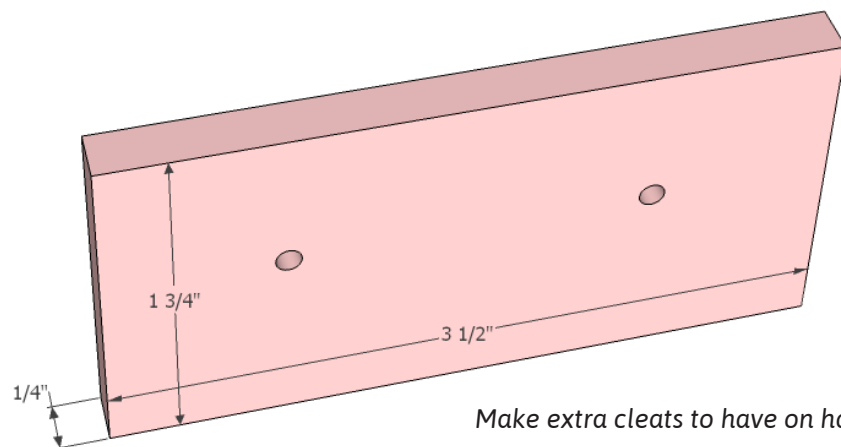
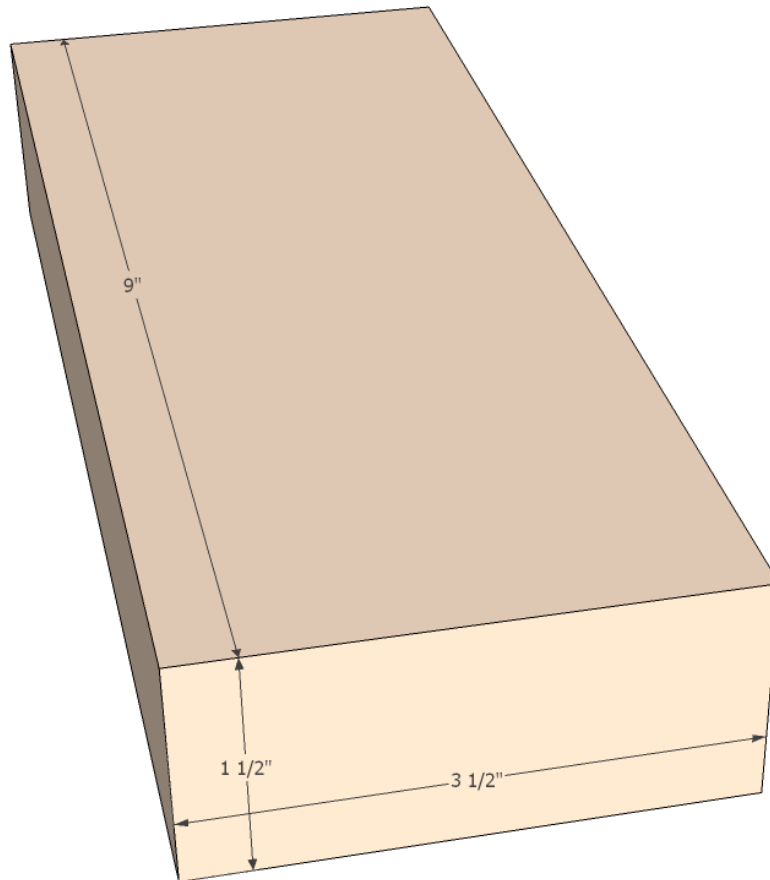

Make extra cleats to have on hand.

Attach handle and cleat.

